

**iQ100, built-in fridge-freezer with  
freezer at bottom, 177.2 x 54.1 cm,  
sliding hinge  
KI38VX22GB**



**Included accessories**

1 x butter dish

iQ 300 built-in fridge freezer for crisper fruit and vegetables thanks to the drawer with wavy bottom.

- ✓ Fresh Box: vegetable drawer with wave bottom
- ✓ Fresh drawer with a corrugated bottom keeps freshness of fruits and vegetables much more longer than standart freshness system.
- ✓ freshSense uses sensors to keep the inside temperature steady, for guaranteed longer food freshness.
- ✓ The fruit and vegetables stay crispy in the drawer with wavy bottom.
- ✓ 3 transparent freezer drawers provide plenty of space and an optimum view.

**Features**

**Technical Data**

Built-in / Free-standing : Built-in  
 Number of compressors : 1  
 Number of independent cooling systems : 1  
 Width of the appliance : 541 mm  
 Depth of the product : 545 mm  
 Net weight : 56.913 kg  
 Required niche size for installation (HxWxD) : 1775.0 x 562.0 x 550 mm  
 Door panel options : Not possible  
 Door hinge : Right reversible  
 Number of Adjustable Shelves in fridge compartment : 4  
 Shelves for Bottles : No  
 Frost free system : No  
 Interior ventilator : No  
 Reversible Door Hinge : Yes  
 Length electrical supply cord : 230 cm  
 Noise level : 40 dB(A) re 1 pW  
 Multi-Flow Air Tower : No  
 Fast cooling switch : No  
 Fast freezing switch : Yes  
 Temperature Controlled Drawer : No  
 Humidity Control Drawer : No  
 Number of Door Bins - Refrigerator : 5  
 Door bin adjustability - Refrigerator : No  
 Tilt-out door bins in fridge : Yes  
 Gallon Storage : Yes  
 Number of Gallon storage : 5  
 Motorized Shelf : No  
 Material of the shelves : Safety glass  
 Door opened indicator freezer : No  
 Automatic motor-driven ice-maker : No  
 Connection Rating : 90 W  
 Fuse protection : 13 A  
 Voltage : 220-240 V  
 Frequency : 50 Hz  
 Storage Period in Event of Power Failure (h) : 7 h  
 Approval certificates : CE, VDE  
 Main colour of product : N/A  
 Door panel options : Not possible  
 Noise level : 40 dB(A) re 1 pW  
 Energy consumption annual - NEW (2010/30/EC) : 275.00 kWh/annum  
 Refrigerator Net capacity - NEW (2010/30/EC) : 217 l  
 Freezer Net capacity - NEW (2010/30/EC) : 59 l  
 Frost free system : No  
 Freezing capacity) - NEW (2010/30/EC) : 6 kg/24h  
 Energy Star Qualified : No  
 Approval certificates : CE, VDE  
 Plug type : GB plug  
 Required cutout/niche size for installation (in) : x x  
 Dimensions of the packed product : 73.22 x 24.40 x 25.19  
 Net weight : 125.000 lbs  
 Gross weight : 136.000 lbs

**iQ100, built-in fridge-freezer with  
freezer at bottom, 177.2 x 54.1 cm,  
sliding hinge  
KI38VX22GB**

#### Features

##### Performance and consumption

###### Design

- Easy clean interior

###### Comfort and Safety

- LED electronic control
- LED electronic control (Digital readout)
- Automatic defrost in fridge section

###### Fridge Section

- 5 safety glass shelves of which 4 are height adjustable
- 5 large door shelves

###### Freshness System

- Vegetable container with wavy bottom

###### Freezer Section

- 3 transparent freezer drawers
- Freezing calendar

###### Dimensions

- Dimensions: H 177.2 cm x L 54.1 cm x D 54.5 cm
- Niche Dimension H X W x D: 177.5 cm x 56.2 cm x 55 cm

###### Technical Information

- Door right hinged, reversible Door
- Connection load: 90 W
- Rated Voltage 220 - 240 V

###### Country Specific Options

- Based on the results of the standard 25-hour test. Actual consumption depends on usage/position of the appliance.

**iQ100, built-in fridge-freezer with  
freezer at bottom, 177.2 x 54.1 cm,  
sliding hinge  
KI38VX22GB**

Dimensioned drawings

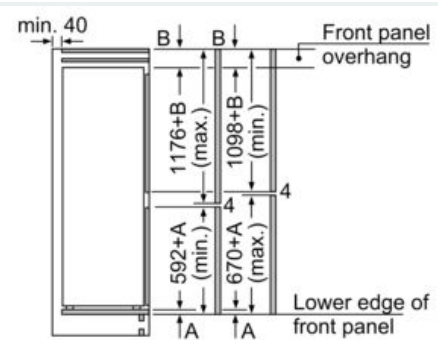
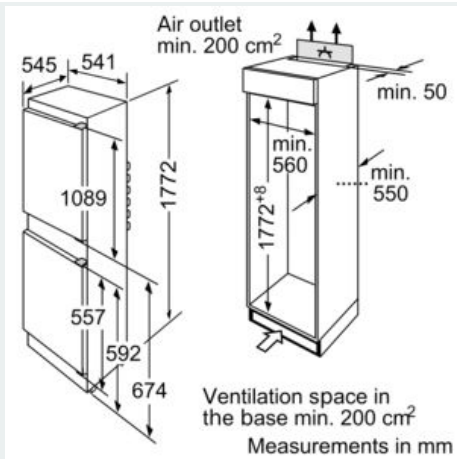

The specified unit door dimensions are valid for a door gap of 4 mm.  
measurements in mm

